



HygroMATIK®

SteamKit E

Electrode Steam Humidifier



Manual



KITE.EN
E-8881176

Certain computer programs contained in this product [or device] were developed by HygroMatik GmbH ("the Work(s)").

Copyright © HygroMatik GmbH [31.07.2019]

SteamKit E

KIT E02/06/10/15/20

All Rights reserved.

HygroMatik GmbH grants the legal user of this product [or device] the right to use the Work(s) solely within the scope of the legitimate operation of the product [or device]. No other right is granted under this licence. In particular and without prejudice to the generality of the foregoing, the Work(s) may not be used, sold, licensed, transferred, copied or reproduced in whole or in part or in any manner or form other than as expressly granted here without the prior written consent of HygroMatik GmbH.

Information in this manual is subject to change or alteration without prior notice.

 WARNING**Risk of electrical shock!**

Hazardous electrical voltage!

All electrical work to be performed by certified expert staff (electricians or expert personnel with equivalent training) only.

1. Introduction	5
1.1 Typographic Distinctions	5
1.2 Documentation	5
1.3 Symbols in Use	5
1.3.1 Specific Symbols related to Safety Instructions	5
1.3.2 General Symbols	5
1.4 Intended Use	6
2. Safety Instructions	7
2.1 Guidelines for Safe Operation	7
2.1.1 Scope	7
2.1.2 Unit control	7
2.1.3 Unit Operation	7
2.1.4 Mounting, dismantling, maintenance and repair of the unit	8
2.1.5 Electrical	8
2.2 Disposal after dismantling	8
3. Transport	9
3.1 Overview	9
3.2 Packing	9
3.3 Interim Storage	9
3.4 Check for complete and correct delivery of goods	9
4. Functional Description and Device Composition	10
4.1 Mode of Action	10
4.2 Mechanical Construction	10
4.3 Operating sequence	11
5. Mechanical installation	12
5.1 Environment parameters to be met	12
5.2 Mounting recommendations	12
5.3 Dimensions	13
5.4 Unit Installation Check	14
5.5 Absorption Distance BN	15
5.5.1 Determining the Absorption Distance	15
5.5.2 Absorption Distance Nomogram	16
5.6 Steam line and condensate hose layout	17
5.6.1 Guide lines for steam line design	17
5.6.2 Condensate hose layout	17
5.6.3 Steam line and condensate hose installation types	18
5.7 Steam Manifold	19
5.7.1 General installation guidelines	19
5.7.2 Recommendations for dimensioning	19
6. Water connection	22
6.1 Water supply	23
6.2 Water discharge	23
6.3 Water connections final check	23

7. Electrical connection	24
7.1 Electrical installation approach	24
7.2 Safety interlock	25
7.3 Connection diagrams	25
8. Commissioning	26
9. Maintenance	27
9.1 General	27
9.1.1 Safety instructions for maintenance	27
9.2 Maintenance frame work	28
9.3 Removal and reinstallation of the steam cylinder	29
9.4 Steam cylinder, electrodes and cylinder base cleaning	32
9.5 Checking cable connections	32
9.6 Solenoid valve removal/reinstallation and fine filter cleaning	33
9.7 Cleaning of blow-down pump	34
9.8 Inspection of hoses	34
9.9 Electrode replacement	35
9.10 Functional check	36
10. Dismantling	37
11. Spare parts	38
12. Exploded view	40
13. Technical specifications	43

1. Introduction

Dear Customer,

Thank you for choosing a HygroMatik steam humidifier kit (referred to as „kit“ in the descriptions following hereafter).

HygroMatik kits represent the latest in humidification technology.

In order to operate your kit safely, properly and efficiently, please read these operating instructions.

Employ your kit only in sound condition and as directed. Consider potential hazards and safety issues and follow all the recommendations in these instructions.

If you have additional questions, please contact your expert dealer.

For all technical questions or spare parts orders, please be prepared to provide unit type and serial number (see name plate on the unit).

1.1 Typographic Distinctions

- preceded by a bullet: general specifications
- » preceded by an arrow: Procedures for servicing or maintenance which should or must be performed in the indicated order
- ☑ Installation step which must be checked off.
- italics* Terms used with graphics or drawings

1.2 Documentation

Retention

Please retain these operating instructions in a secure, always accessible location. If the product is resold, turn the documentation over to the new operator. If the documentation is lost, please contact HygroMatik.

Versions in Other Languages

These operating instructions are available in several languages. If interested, please contact HygroMatik or your HygroMatik dealer.

Co-applicability

If the kit is ordered and delivered with a HygroMatik control, the manual of that control must be regarded as an applicable document.

1.3 Symbols in Use

1.3.1 Specific Symbols related to Safety Instructions

According to ANSI Z535.6 the following signal words are used within this document:



DANGER indicates a hazardous situation which, if not avoided, will result in death or serious injury.



WARNING indicates a hazardous situation which, if not avoided, could result in death or serious injury.



CAUTION indicates a hazardous situation which, if not avoided, could result in minor or moderate injury.



NOTICE is used to address practices not related to physical injury.

1.3.2 General Symbols

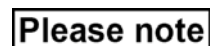

This symbol is used whenever a situation requires special attention beyond the scope of safety instructions.

1.4 Intended Use

The kit serves for steam production based on tap water or partially softened water.

Only use supply water featuring a conductivity of 125 to 1250 $\mu\text{S}/\text{cm}$.

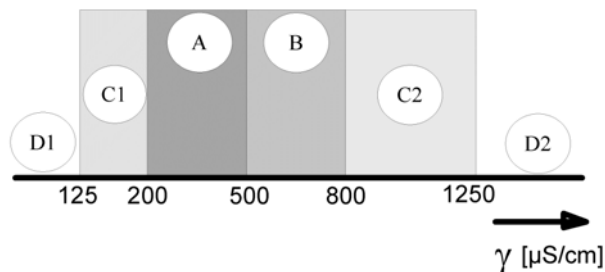

D1: Lower threshold

C1: Range of reduced conductivity
(adjustment required)

A: Normal Tap water

B: Range of increased conductivity

C2: Range of high conductivity
(adjustment required)

D2: Upper threshold

In the C1 and C2 ranges, adaptation of the periodic blow-down frequency may be required.

Proper usage also comprises the adherence to the conditions specified by HygroMatik for:

- installation
- dismantling
- reassembly
- commissioning
- operation
- maintenance
- disposal.

Only qualified and authorised personnel may operate the unit. Persons transporting or working on the unit must have read and understood the corresponding parts of the Operation and Maintenance Instructions and especially the chapter 2. „Safety Notes“. Additionally, operating personnel must be informed of any possible dangers. You should place a copy of the Operation and Maintenance Instructions at the unit's operational location (or near the unit).

By construction, the kit is not qualified for exterior application.

⚠ WARNING

Risk of scalding!

Steam with a temperature of up to 100 °C is produced.

Do not inhale steam directly!

2. Safety Instructions

These safety instructions are required by law. They promote workplace safety and accident prevention.

2.1 Guidelines for Safe Operation

2.1.1 Scope

Comply with the accident prevention regulation „DGUV Regulation 3“ to prevent injury to yourself and others. Beyond that, national regulations apply without restrictions.

2.1.2 Unit control

Do not perform any work which compromises the safety of the unit. Obey all safety instructions and warnings present on the unit.

In case of a malfunction or electrical power disruption, switch off the unit immediately and prevent a restart. Repair malfunctions promptly.

2.1.3 Unit Operation

▲ WARNING**Risk of scalding!**

Uncontrolled hot steam escape in case of leaking or defective components possible. Switch off unit immediately.

NOTICE**Risk of material damage!**

The unit may be damaged if switched on repeatedly following a malfunction without prior repair.

Rectify defects immediately!

The unit must not be operated on a DC power supply.

The unit may only be used connected to a steam pipe that safely transports the steam.

Regularly check that all safety and monitoring devices are functioning normally. Do not remove or disable safety devices.

2.1.4 Mounting, dismantling, maintenance and repair of the unit

NOTICE

Make sure that the unit is not object to dripping water in the mounting location.

Installing a kit in a room without water discharge requires safety devices to protect against water leakages.

- Use genuine spare parts only
- After any repair work, have qualified personnel check the safe operation of the unit

2.1.5 Electrical

⚠WARNING**Risk of electrical shock!**

Hazardous electrical voltage!

Any work on the electrical system to be performed by certified expert staff (electricians or expert personnel with comparable training) only.

Disconnect unit components from electrical power supply prior to work.

After electrical installation or repair work, test all safety mechanisms (such as grounding resistance).

NOTICE

Regularly check the unit's electrical equipment. Promptly repair any damage such as loose connections or burned wiring.

Responsibility for intrinsically safe installation of the kit is incumbent on the installing specialist company.

2.2 Disposal after dismantling

NOTICE

The operator is responsible for the disposal of unit components as required by law.

3. Transport

3.1 Overview

Please note

Proceed carefully when transporting the kit in order to prevent damage due to stress or careless loading and unloading.

3.2 Packing

Please note

Pay attention to the icons affixed to the packing box.

3.3 Interim Storage

Store the unit in a dry place and protect from frost and strong sunlight.

3.4 Check for complete and correct delivery of goods

Upon receipt of the unit, confirm that model and serial number on the name plate match those specified in the order and delivery documents.

Scope of delivery

Qty.	Item
1	Console with steam cylinder/ cylinder base, solenoid valve, blow-down pump, internal tubing with elbow
1	SteamKit manual
1	Control Basic (optional)
1	„Control Basic“ manual
1	Control Standard (optional)
1	„Control Standard“ manual
1	Steamhose adaptor
1	O-Ring for steamhose adaptor

Qty.	Item
1	Clamp 20 - 32 mm for wastewater stub
3	Electrode plug
1	Sensor electrode plug
4	Blade receptacle for connection of solenoid valve and blow-down pump
4	Insulating sleeve
1	Ring cable lug for grounding

Pls., check whether the equipment is complete and all parts are in perfect condition.

Please note

A main contactor is not included and must be supplied on-site. For selection, pls. keep max. current draw of the kit in mind as specified in the electrical connection section (section 10).

Claim

In case of damage from shipment and/or missing parts, immediately notify the carrier or supplier in writing.

Time limits for filing freight claims with shipping companies are*:

Shipping company	After receipt of goods
Carriers	no later than 4 days
Parcel service	immediately

* Time limits for some services subject to change.

4. Functional Description and Device Composition

4.1 Mode of Action

Making use of the frictional heat caused by current flow in a water tank

The HygroMatik electrode steam humidifiers utilize the conductivity normally present in tap water for steam production. Electrodes inside an enclosed steam cylinder are immersed directly into the tap water. They are connected to the alternating current.

The conductivity of the water generates an electric current between the electrodes. In this way, the electric power supplied is converted directly into heat without energy loss. The steam produced has a temperature of about 100°C (212°F) with minimal excess pressure ("pressureless steam"). It is largely free of minerals and germ-free. Mineral deposits typically remain behind in the cylinder.

4.2 Mechanical Construction

The kit is designed for wall mounting or for standing on a horizontal level surface.

The device composition is demonstrated by the fig. following hereunder.

For maintenance purposes, the steam cylinder is separable in the middle.

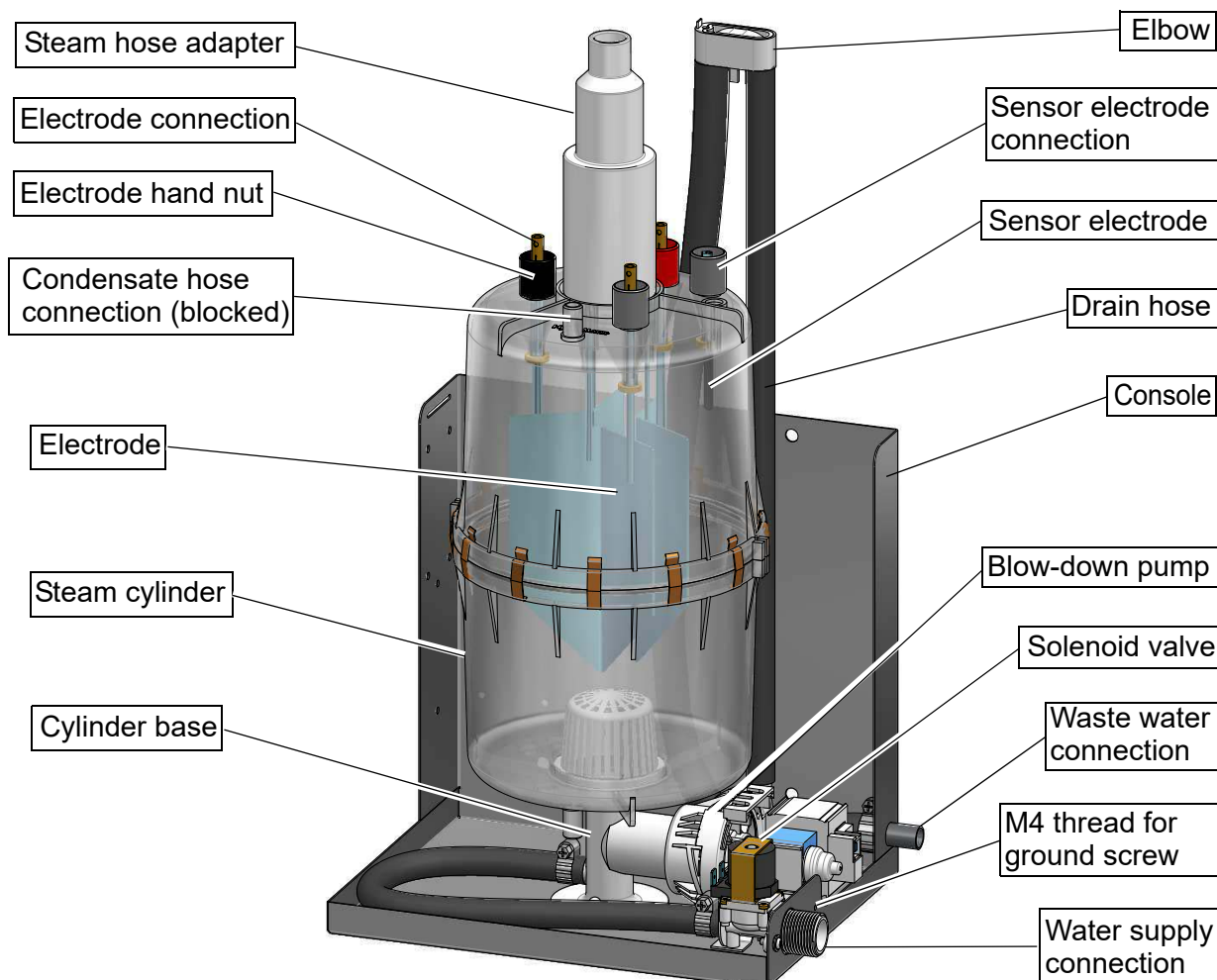

4.3 Operating sequence

The operating sequence is determined by the electrical wiring and control of the kit. Following hereafter is the description of a typical operating sequence when a HygroMatik control „Standard“ is used:

By pressing the control switch („Pos. I“) the humidifier is turned on. When the controller specifies an increase in humidity, the main contactor is switched on and the electrodes (48)^{*)} are supplied with power. The water inlet solenoid valve (25)^{*)} feeds water into the steam cylinder (19)^{*)}.

As soon as the electrodes are immersed, the current begins to flow. The water is now heated. When the pre-selected output is reached, the control turns off the solenoid valve and interrupts the water supply.

After a short period of heating up, the water between the electrodes starts boiling and then vaporizes. The vaporization lowers the water level in the steam cylinder, reducing the output provided. To compensate for that, fresh water is fed into the steam cylinder every now and then by opening the intake solenoid valve.

Humidifier power usage is continuously monitored. With a cold start-up, the nominal current increases to 113 % in order to achieve quick-start output parameters. This activates the electronic overflow limiter which causes a partial draining of the cylinder. This reduces the immersed surface area of the electrodes, lowering power usage.

The concentration of dissolved salts increases over time, which can lead to a rise in the conductivity of the water. This could damage the unit, but in any case would significantly reduce the life span of the electrodes.

For this reason, regular, periodic blow-downs of some of the concentrated water are very important. Following this procedure as recommended provides stable cylinder water conductivity as well as minimal water loss for the expected service life of the cylinder.

Water blow-down is performed by a blow-down pump (32)^{*)}. The functioning of the blow-down pump is continuously monitored during operation. If the pump is damaged, the kit shuts down.

With normal water quality the blow-down loss rate lies between 7 and 15 % of the amount of steam produced. Depending on water quality, a full steam cylinder blow-down is run every 3 to 8 days.

Mineral deposits settle in the open area below the electrodes and are removed through periodic maintenance. The blow-down pump itself has wide openings and can flush out smaller pieces of mineral deposit. This extends the service life of the unit and reduces the required maintenance interval.

On blow-down, water flows from the pump into the drainage system.

For maintenance purposes, the cylinder water may be pumped out by pressing and holding the control switch in the „II“ position.

Monitoring max. level

A sensor electrode (38)^{*)} monitors the maximum water capacity of the cylinder. When the water level reaches the sensor electrode, the water supply is interrupted. This can occur when the water has low conductivity or when the electrodes are worn out. In the case of low water conductivity, however, this state usually lasts only a short time. The built-in control and the large area electrodes combine to produce a rapid rise in conductivity by increasing the concentration of the water.

^{*)} numbers indicated correspond with those in the exploded view in the „Exploded view“ chapter.

5. Mechanical installation

▲ WARNING

Risk of foot injuries!

Prevent unit from dropping during installation! Helping hand of a second person is advisable.

▲ WARNING

Risk of electrical shock!

Hazardous electrical voltage. During installation, the unit must be disconnected from power supply.

5.1 Environment parameters to be met

- By design, the kits are not qualified for outdoor installation since electrical/electro-mechanical/electronic components (depending on configuration variant) and water-bearing parts may be damaged
- Ambient temperature must lie between +5 and +40 °C (+41 and +104 °F) ; frost may damage the steam cylinder, the solenoid valve and pump, as well as make hoses burst
- Relative humidity must not exceed 80 % r.h., since values beyond may lead to electronic malfunction or damage
- Installation in a closed room requires aeration and, eventually, temperature conditioning in order to meet the a.m. environmental conditions

5.2 Mounting recommendations

When selecting the installation site for the steam humidifier, take the following into account:

- The kit should be installed as close as possible to the steam manifold. Optimum performance is only guaranteed when steam and condensate hoses are

kept short

- Make use of existing water connections for supply and draining
- Hoses must be laid at a consistent 5 to 10 % incline/decline; sagging and kinking prevention is a must
- Mount the unit on a stable, preferably solid wall offering the bearing capacity required (s. unit technical specifications) or standing on a horizontal, level surface. If such a wall is not at hand, the unit may be attached to a stand bracket firmly bolted to the floor.
- The steam humidifier console heats up during operation. Take care that the construction on which the unit is to be mounted is not made of temperature-sensitive material.
- The elbow is to be attached to a suitable vertical surface by means of a screw

When selecting the mounting material to be supplied by the customer, attention must be paid to adequate strength. For the correct functioning of the steam humidifier it is required that the device is mounted level and plumb.

After mounting the kit make sure that it sits firmly.

5.3 Dimensions

Table of dimensions

Model	A [mm]	B [mm]	C [mm]	E1 [mm]	E2 [mm]	H1 [mm]	H2 [mm]	H3 [mm]	H4 [mm]	L1 [mm]	L2 [mm]
KIT E02	300	220	400	157,5	125	30	25	42	226	15	185
KIT E06	300	220	530	157,5	125	30	25	42	226	15	185
KIT E10	300	220	550	157,5	125	30	25	42	226	15	185
KIT E15	300	285	730	270	270	35	25	80	160	15	250
KIT E20	350	285	730	270	270	35	25	80	160	15	250

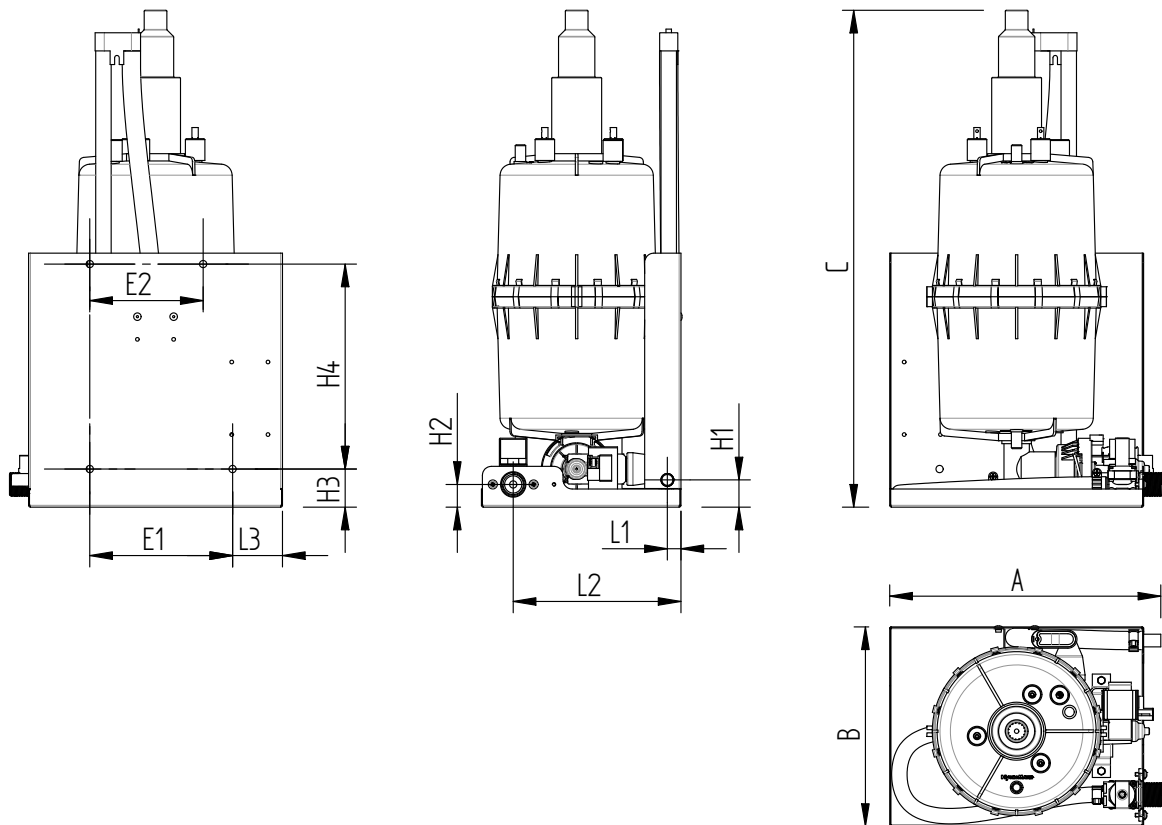

5.4 Unit Installation Check

Before start-up, pls. check proper unit installation following the list below:

- Kit perpendicularly aligned in both the vertical and horizontal axis ?
- Steam hose installed with a 5 - 10 % minimum incline/decline (see chapter "Steam line") ?
- Condensate hose features a loop functioning as a steam barrier (see chapter „Condensate hose“) ?
- Steam manifold(s) properly positioned?
- All bolts and clamps properly tightened?
- Steam manifold(s) horizontally mounted and suspended on the free end, if required ?
- All seals (o-rings) in place?

5.5 Absorption Distance B_N

The "absorption distance" (B_N) is defined as the distance from the steam feed to where the steam is completely absorbed in the treated air. Within the absorption distance, steam is visible as mist in the air stream.

Condensation may occur on anything installed within the absorption distance.

Although steam outside the absorption distance (B_N) is completely absorbed, it is not yet evenly diffused in the duct. If you plan to install any parts or devices inside the absorption distance, such as sensors or elbows, we recommend increasing the absorption distance using the formulae below. The absorption distances required for certain installed fittings are distinguished by separate symbols and calculated as a multiplier of the absorption distance B_N .

Absorption Distance	
B_N	for normal obstructions such as sensors, ventilators, outlets
$B_C = (1.5...2) \times B_N$	for fine filters, heat registers
$B_S = (2.5...3) \times B_N$	for particle filters
$B_d = (3...5) \times B_N$	for humidity sensors, duct humidistats

The absorption distance has no fixed value, but depends on many factors. These are depicted in the absorption distance nomogram below.

5.5.1 Determining the Absorption Distance

To determine the absorption distance, the following parameters are required:

- Air humidity before humidification x_1 in g/kg
- Air temperature after humidification t_2 in °C (with steam humidifiers the change in air temperature due to humidification may be disregarded t_1 or t_2)
- Specific increase in humidity Δx in g/kg (can be determined in the h,x diagram)

- quantity of steam introduced $\overset{o}{m}_D$ in kg/h.
- air speed w_L in m/s in air duct
- Total length l_D of the steam manifold installed in the air duct

Length l_D of the usable steam manifold depends on the dimensions of the air duct. The length of the absorption distance can be reduced by using multiple steam manifolds (also see section on the steam manifold).

Method:

Graphically determine absorption distance B_N using the absorption distance nomogram (also see Section „Absorption Distance Nomogramm“). Enter the value of the parameters enumerated above into the respective quadrants. The resulting point of intersection indicates the value of the desired absorption distance B_N .

Notes:

Air humidity before humidification x_1 :.....[g/kg]

Air temperature after humidification t_2 :.....[°C]

Specific increase in humidity Δx :.....[g/kg]

Quantity of steam introduced $\overset{o}{m}_D$:.....[kg/h]

Air speed w_L :.....[m/s]

Total length of steam manifold l_D :.....[mm]

5.5.2 Absorption Distance Nomogram

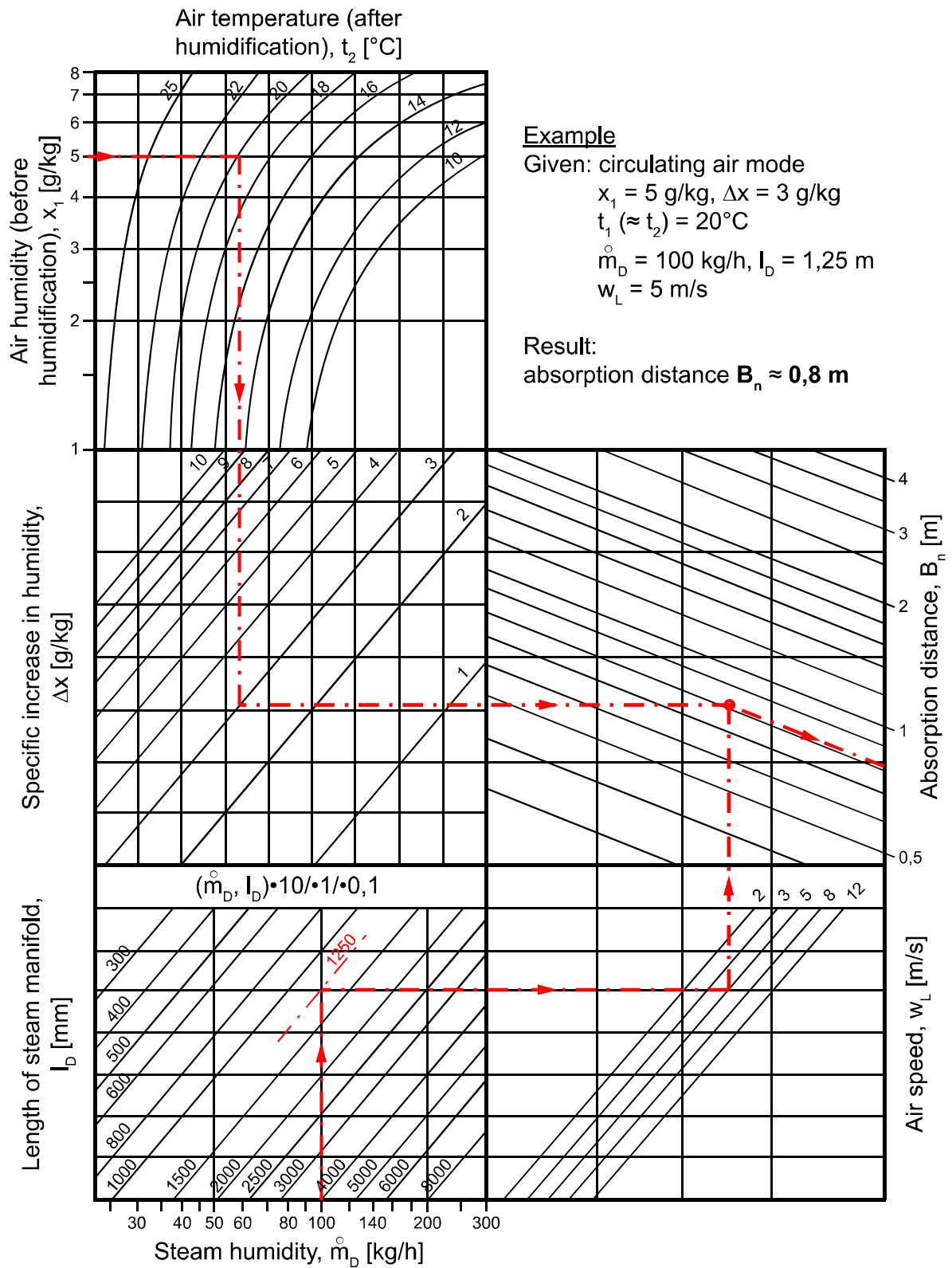

Source: Henne, Erich: Luftbefeuchtung (Air Humidification), 3rd Edition 1984 (Page 101), Oldenbourg Industrieverlag, Munich

5.6 Steam line and condensate hose layout

Please note

Because of the high requirements on hose material under the operating conditions given, it is recommended to use genuine HygroMatik hoses only.

5.6.1 Guide lines for steam line design

- Steam hose nominal diameter must not be smaller than the steam outlet of the HygroMatik steam humidifier (do not restrict the cross-section, otherwise back pressure will increase)
- Steam hoses must be laid without sags and kinks and with a continuous slope of 5-10% (otherwise sags may result).
- Steam hoses must be supported every 500 mm by clamp brackets
- Steam hoses should be kept as short as possible. Implement lengths beyond 5m as insulated fixed piping to keep energy loss and condensate generation to a minimum. Fixed piping is generally recommended for straight steam line segments
- When 2 steam manifolds are in use (other than with a standard implementation), place steam Y piece as close as possible to the steam manifolds. Such, for the main part of the piping just one steam hose is required and condensate loss is minimized. Some models of the HygroMatik steam humidifier portfolio, however, require that the Y-piece is mounted as close as possible to the steam exit with 2 steam lines (this is the case for e.g. FLE40 and FLE80)
- Allow easy access to the steam pipe/ steam hose installation
- Pressure conditions within the duct are influenced by device steam output, steam line layout and the duct composition itself. In some rare situations it may become necessary to optimize steam line layout for achieving the

results intended

- Respect minimum bending radii:
DN 25 Steam hose: Rmin = 200 mm
DN 40 Steam hose: Rmin = 400 mm

5.6.2 Condensate hose layout

The condensate hose may be run from the steam manifold back to the steam cylinder, as depicted in the schematic drawing below with concern to installation type 1. Alternatively, the condensate hose may be fed directly in a wastewater pipe or a drain (s. installation type 2).

Please note

Should condensate return into the steam cylinder be intended, the connection stub on the cylinder upper part must be drilled out first with a ANSI drill size „O“ drill. To do so, the steam cylinder must be removed from the housing (s. maintenance chapter, section „Steam cylinder removal and reinstallation“).

Drill out condensate hose connection stub with an 8 mm (ANSI drill size „O“) drill, if required

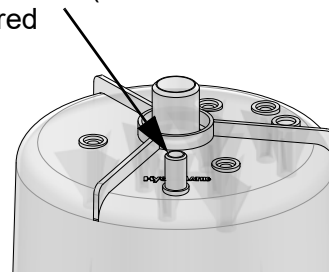

Steam cylinder top view

5.6.3 Steam line and condensate hose installation types

Installation type 1

Steam manifold is positioned more than 500 mm above device upper edge:

- » Run steam hose to a height of 400 mm minimum above the steam humidifier and then to the steam manifold with a continuous incline of 5 to 10 %.
- » Feed condensate hose from steam manifold with a decline into waste-water pipe or drain.
- » As a steam barrier, lay out a 200mm min. loop (s. schematic representation below). Minimum distance from steam manifold to loop must be 500 mm. Fill loop with water prior to steam humidifier commissioning.

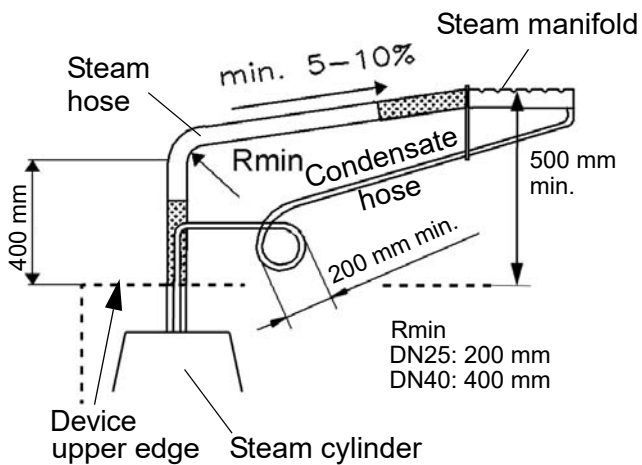

**Installation type 1,
schematic representation**

Installation type 2

Steam manifold is positioned less than 500 mm above or below device upper edge:

Please note

In this arrangement the condensate hose cannot be fed back to the steam humidifier.

- » Run steam hose to a height of 400 mm minimum above the steam humidifier and then to the steam manifold with a continuous decline of 5 to 10 %.
- » Feed condensate hose to a waste-water pipe/drain with a 200 mm diameter loop as a steam barrier. Minimum distance from steam manifold to loop must be 500 mm. Fill loop with water.

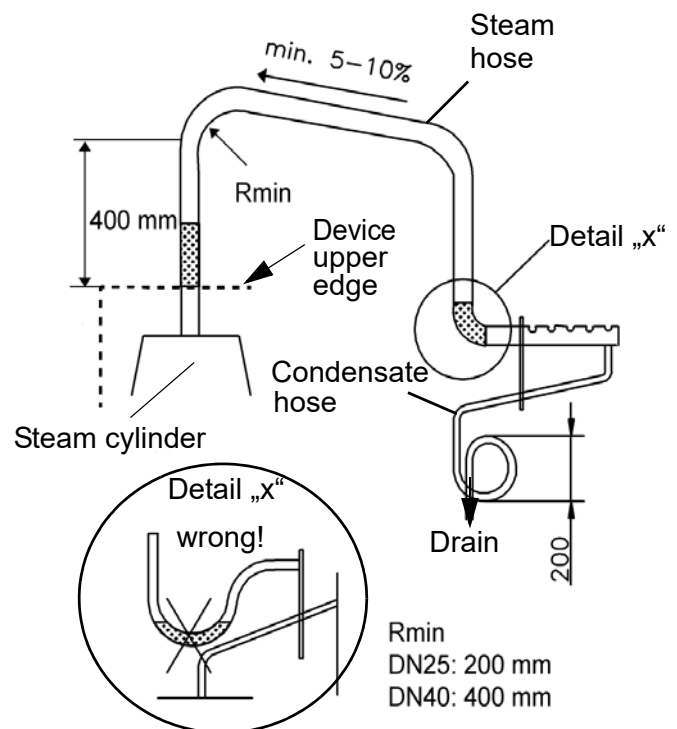

**Installation type 2,
schematic representation**

5.7 Steam Manifold

5.7.1 General installation guidelines

When installing steam manifolds, pls. follow these guidelines:

Positioning within duct

- Install the steam manifold as close as possible to the steam humidifier in order to minimize steam loss through condensation
- Steam manifold placement on the supply side of the air duct is preferable
- Install steam manifold strictly horizontal in order to ensure proper condensate drain
- Shown installation and positioning dimensions are based on empiric values. Special environmental conditions may require adjustments. Pay special attention to avoid condensate generation in air duct

Allowable pressures

- Max. allowable pressure in air duct is 1500 Pa/.218 PSI (exemption: SLE02, SLH02, KIT E02 and KIT H02 only allow for 1200 Pa/.174 PSI)
- On suction side, max. -500 Pa (.07 PSI) is tolerable
- With high-pressure air conditioning systems, modifications of the unit's drain hose system may possibly be required depending on the overall pressure situation. These modifications must be **coordinated with your expert dealer.**

Water drain

- We point out that according to the German Association of engineers (VDI) guideline VDI 6022, a water drain must be provided within the absorption distance inside the air duct

When increased airflow speed is encountered

- Air flow rates beyond 3m/s (9.84 ft/s) may lead to condensate drainage problems at the steam manifolds due to vacuum built-up. A possible remedy is twisting the steam manifold in its horizontal axis by few angular degrees. In case of problems, pls. consult your expert dealer.

5.7.2 Recommendations for dimensioning

The recommendations given below are based on homogenous air flow in the duct.

Horizontal installation of steam manifold

Standard steam manifold arrangement:

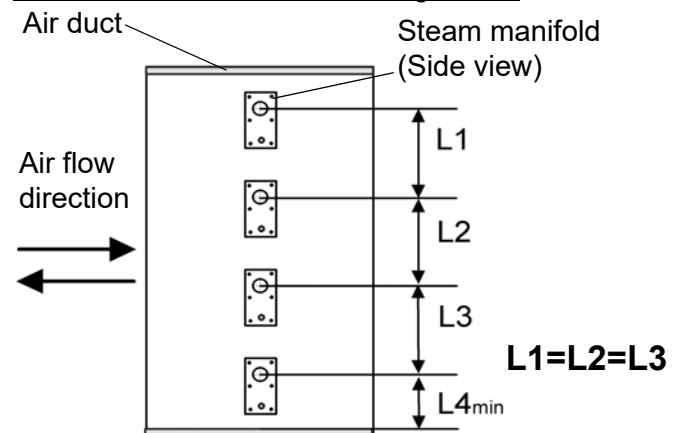

An even distribution of steam manifolds ensures a uniform steam distribution.

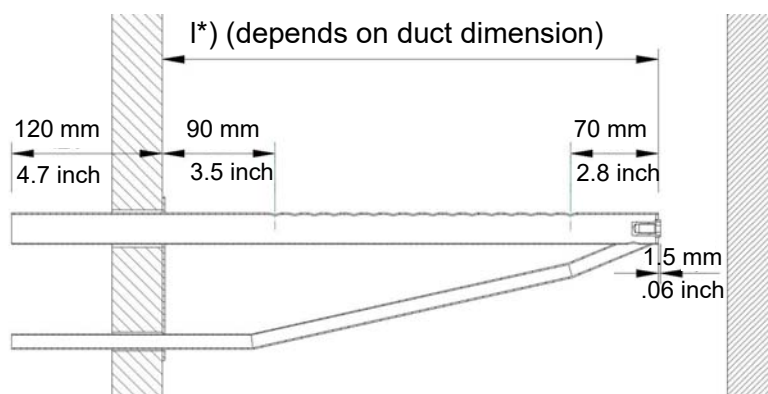

Please use the total height of the duct!

*) s. table of manifold lengths **Horizontal assembly position in duct**

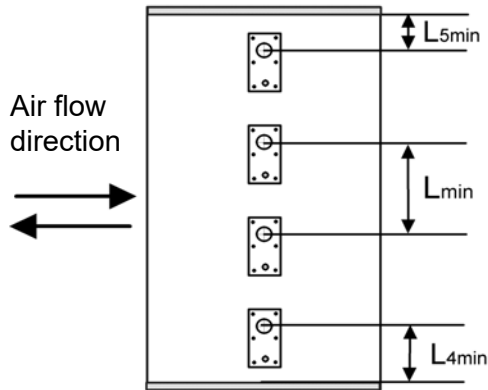

Minimum distance for condensation avoidance:

$L_{min} = 210mm/8.3 \text{ inch}$: „Steam manifold - Next steam manifold“ distance

$L_{4min} = 120mm/4.7 \text{ inch}$: „Lowest steam manifold - Duct bottom plane“ distance

$L_{5min} = 120mm/4.7 \text{ inch}$: „Highest steam manifold - Duct ceiling plane“ distance

Steam manifold arrangement for special air duct shapings

flat	steam manifold laterally staggered (with respect to air flow direction) in case of L_{min} (s. above) not to be met	<p>Air flow direction</p>																
very flat	<p>by tilting the steam manifold 30 - 45° towards the air flow direction, the minimum upper clearance can be reduced to 70 mm/2.8 inch.</p> <table border="1" data-bbox="384 1429 906 1617"> <thead> <tr> <th>Min[mm/inch]</th> <th colspan="2">H1</th> <th>H2</th> </tr> <tr> <td></td> <th>30°</th> <th>45°</th> <td></td> </tr> </thead> <tbody> <tr> <td>DN25/1"</td> <td>182/7.2</td> <td>168/6.6</td> <td>225/8.6</td> </tr> <tr> <td>DN40/1 1/2"</td> <td>193/7.6</td> <td>179/7.2</td> <td>230/9.1</td> </tr> </tbody> </table>	Min[mm/inch]	H1		H2		30°	45°		DN25/1"	182/7.2	168/6.6	225/8.6	DN40/1 1/2"	193/7.6	179/7.2	230/9.1	<p>narrow channel</p> <p>Air flow direction</p>
Min[mm/inch]	H1		H2															
	30°	45°																
DN25/1"	182/7.2	168/6.6	225/8.6															
DN40/1 1/2"	193/7.6	179/7.2	230/9.1															
narrow, high	identical lengths one on top of the other, staggered laterally if possible																	
square	identical lengths, staggered vertically and laterally																	
low, very wide	facing each other																	

Vertical steam manifold installation

Steam manifold arrangement

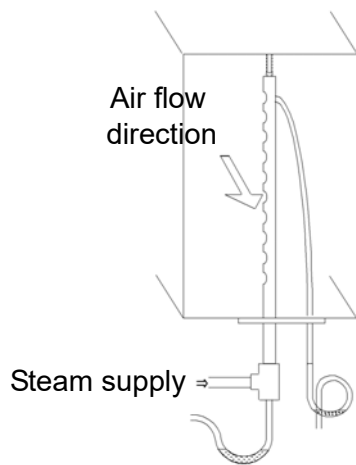

Horizontal installation of the steam manifolds is preferable. However, vertical installation into the air duct from below is also possible.

Standard manifold dimensions [mm]/ [inch]:**

220/ 8.7	400/ 15.7	600/ 23.6	900/ 35.4	1200/ 47.2	1450/ 57.1
---------------------	----------------------	----------------------	----------------------	-----------------------	-----------------------

*** Special lengths on demand.

Number and size of the steam manifolds available as well as the nominal diameter of the respective steam and condensate hoses may be taken from the tables shown in chapter „Technical Data“.

6. Water connection

▲WARNING**Risk of scalding!**

Very hot water to be found in and around the kit during and after operation.

Have all installation work done by expert staff in order to avoid scalding hazards due to improper water guidance.

▲WARNING**Risk of electrical shock!**

Hazardous electrical high voltage!

Before starting installation work ensure that the unit is not yet connected to the power supply.

General Rules

- Obey local water utility regulations
- Verify that necessary safety measures have been taken – in compliance with either German Technical and Scientific Association for Gas and Water (DVGW) guidelines (DIN EN1717) or local regulations – to eliminate backflow of polluted water into drinking water treatment facilities. This may require the installation of a system separator and free discharge into the drainage system
- Supply water must not exceed 40 °C (104 °F)
- Allowable range of water pressure: 100000 to 1000000 Pa (14.5 to 145 psi)
- For connection to the water supply pipe, make use of a water hose
- Blow-down water must drain freely
- Min. conductivity of the supply water must be 3 S/cm

6.1 Water supply

NOTICE

Foreign material in water supply pipe may cause premature wear of the solenoid valve.

Flush the water supply pipe before making connection to the solenoid valve. This is of particular importance in case of a newly installed pipe.

On-site, a shut-off valve and - if required by the water quality - a water filter in the supply line is to be installed. Use a connection hose with a 3/4" cap nut für connection to the water inlet (solenoid valve) of the kit.

Water pressure of the supply line is allowable from 1 to 10 bar (100×10^3 to 100×10^4 Pascal, 14.5 to 145 psi).

Please note

Strainer must be placed inside the solenoid valve.

6.2 Water discharge

⚠ WARNING

Risk of scalding!

During blow down up to 0.3 l/sec (.08 gal./sec) are being drained with a temperature of about 95 °C (203 °F).

Ensure that the drain hose is reliably fastened and wastewater can drain freely and pressureless.

Please note

Humidifier kit installation location and wastewater discharge must be on the same pressure level.

Guidelines for water discharge composition

- Do not buckle drain hose
- Discharge line and drain pipe material must be temperature resistant up to 95 °C (203 °F)

How to proceed

- » Fit 14 mm (.55 inch) drain hose with a clamp to the wastewater connection and run into a pressure-free outlet according to DIN EN 1717.

6.3 Water connections final check

Go down the following water installation checklist:

- All screws and clamps properly tightened?
- Water supply line flushed before making connections?
- Water connection properly installed?
- Water discharge properly installed?
- Does blow-down water drain freely?
- Water supply line and water discharge leakage-free?

7. Electrical connection

⚠ WARNING

Danger of electrical shock!

Dangerous electrical voltage!
All work relating to the electrical installation may only be carried out by designated specialist personnel (electrician or qualified person with equivalent training).

Do not connect the steam humidifier to the live power supply before all installation work has been completed.

Please note

The customer is responsible for monitoring the qualifications of the specialist personnel.

General installation rules

- All local rules concerning the implementation of electrical installations must be obeyed
- Electric connector cables to be laid professionally
- Install the electrical connections according to the wiring diagram

NOTICE

Possible electronical components destruction through electrostatical discharge!

Prior to commencing electrical installation work, steps must be taken to guard the sensitive electronical components of the unit control against damage from electrostatical discharge.

7.1 Electrical installation approach

- » Provide fuses with a contact gap of at least 3mm per pole.
- » Make main connection according to the table below.

Main connection

For the particular model of the kits, main connection is to be implemented as follows:

Model	Main connection
KIT E02 KIT E06	208 - 240 VAC/1~/N/ 50 - 60 Hz
KIT E06 KIT E10 KIT E15 KIT E20	380 - 415 VAC/3~/ 50 - 60 Hz

Other operating voltages on request.

Fusing

HygroMatik recommends the use of slow blowing up to middle time-lag main fuses (only applies to the a.m. mains supply voltage).

Please note

The kit installation should incorporate an individual residual current device (RCD).

Maximum current draw of the kit models and the required fusing resulting from that can be taken from the table below.

Model	Current draw [A]	Fusing [A]
KIT E02	6.5	1x10
KIT E06	15	1x20
KIT E06	6.5	3x10
KIT E10	10.8	3x16
KIT E15	16.3	3x20
KIT E20	21.7	3x32

7.2 Safety interlock

The descriptions following hereafter relate to the usage of a kit in combination with a HygroMatik control.

⚠ WARNING

Risk of electrical shock!

Hazardous electrical voltage!

When standard wiring was made, terminal 1 shows 208 - 240 VAC after commissioning.

Across terminal 1 and 2 the so-called safety interlock is wired. This wiring allows for integration of safety devices. In case of an open safety interlock the steam humidifier does not operate.

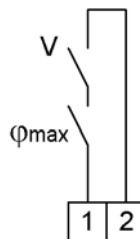

Safety interlock terminals 1/2

Please note

Factory setting leaves the safety interlock open!

Install contact interlocks, e.g. a max. hygro-

stat in series across terminal 1 and 2.

Please note

Contacts across terminals 1 and 2 must be potential free and rated for 240 VAC.

Best practice implies the integration of a max. hygrostat in the safety interlock wiring to protect against over-humidification due to a r.h. sensor malfunction.

7.3 Connection diagrams

In case of a HygroMatik control „Basic“ or „Standard“ to be used with the kit, the according connection diagram can be found in the respective manual and must be followed. For all other types of use, the connection of the electrical components is the responsibility of the customer.

8. Commissioning

The descriptions given hereafter particularly relate to the usage of a kit with the Control Standard and - with the exemption of step 3 - Control Basic.

▲WARNING

Risk of operating error!

Start-up of the unit is restricted to expert staff only (electricians or expert personnel with equivalent training).

Step 1: Check of mechanical integrity and wiring

- » Check cylinder seating.
- » Check steam, condensate and drainhose clamps.
- » Check that all electrical wire connections (including steam cylinder wiring) are tight and secure.

Step 2: Switching on the steam humidifier

- » Switch on main breaker.
- » Open water supply stopcock (operating pressure should be 1bar min., 10bar max.).
- » Switch on unit by setting control switch to "I".

Step 3: The unit performs a self-test and, then, commences normal operation

- During self-test, the display flashes for a couple of seconds (only with Control Standard)
- On completion of the test, the software version is displayed for a short moment (only with Control Standard). Consequently, normal operation is commenced. However, steam is not produced

Step 4: Trigger steam demand

- » Set control to 1-step operation, i.e. permanent steam demand, and close safety interlock.
- The water inlet solenoid valve opens and feeds water into the steam cylinder

Step 5: Monitor unit function and check for leakage

- » Let unit operate for 15 to 30 minutes.
- » If leaks appear, switch off the unit.

▲WARNING

Risk of electrical shock!

Hazardous electrical voltage!
Follow safety instructions for work on live components.

Step 6: Repair leaks

- » Find leaks and eliminate.
- » Check again for leaks.

9. Maintenance

9.1 General

For the achievement of a long unit life span, regular maintenance is a must. Maintenance works to be performed refer to unit assemblies that underlie either mechanical or electrical wear and tear, or may be impeded by residues in their proper functioning.

The steam humidifier's performance and maintenance intervals primarily depend on the water quality encountered and the amount of steam produced. A particular water quality may shorten or lengthen maintenance intervals. The amount of residues found in the steam cylinder allows for a hint on future maintenance intervals.

As part of the maintenance work, screw terminals and plug connections must be checked every time. If required, retightening the terminal screws is a must as well as ensuring tight fit of all of the plug connections.

Since steam and condensate hoses are subject to wear as well, hoses must also be checked regularly.

Seals are wear parts. As such, seal integrity checks and replacement if required, is also a part of the regular maintenance work (s. spare parts section -> O-ring sets).

9.1.1 Safety instructions for maintenance

▲WARNING

Risk of electrical shock!

Hazardous electrical voltage. Unit must be switched off and protected against restart by expert staff (electricians or expert personnel with equivalent training) before any maintenance work is commenced.

▲WARNING

Risk of skin burning!

Hot steam cylinder during operation and for some time afterwards.

Drain steam cylinder before any maintenance work is commenced. After that, wait approx.

10 mins before starting maintenance work. Check steam cylinder temperature by cautious approximation with hand (do not touch!).

▲WARNING

Risk of scalding!

Water pumped or drained from the steam cylinder may have a temperature of up to 95 °C (203 °F).

Wear proper PPE (Personal Protection Equipment)!

The notice following hereafter is of particular significance when a HygroMatik control is used. It is a general rule, however, whenever electronic components are in use.

NOTICE

Take care of ESD protection!

The electronic components of the humidifier control are very sensitive to electrostatic discharges. In order to protect these components during maintenance, steps must be taken to guard against damage from electrostatic discharge.

9.2 Maintenance frame work

Mineral deposits precipitate and crystallize very differently in different types of water, even when two types have the same conductivity and hardness levels (the various constituents in the water interact differently).

Instructions on maintenance and cleaning intervals, or on electrode service life, are based entirely on empirical data.

In most cases, the conductivity levels given in the "Directions for Use" section of this manual may be considered as typical values. Individual parameter settings as part of the control software may be necessary.

Very seldomly, water pretreatment may be necessary (softening by dilution to approx. 4 - 8 °gH; decarbonization/partial desalination to achieve target reductions in carbonate hardness).

For any questions with regard to water treatment systems pls. contact your expert dealer.

Cycle time	Maintenance work
4 weeks after commissioning (with normal water quality)	Visual inspection of electrical and mechanical connections Remove mineral deposits from steam cylinder, water drain hose and blow-down pump Check electrodes for burn-off Re-tighten electrode hand nuts and all screw terminals
semiannually (with normal water quality and "normal" operation, i.e. 8 hours per day)	Visual inspection of electrical and mechanical connections Remove mineral deposits from steam cylinder, water drain hose and blow-down pump. Check electrodes for burn-off and replace, if required. Re-tighten electrode hand nuts and all screw terminals

9.3 Removal and reinstallation of the steam cylinder

Steam cylinder removal

- » Drain cylinder water making use of blow-down pump.



Disconnect unit from power supply

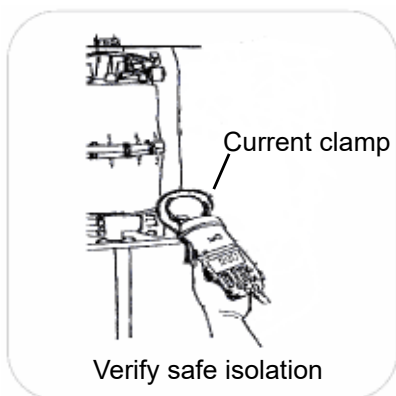

Verify safe isolation

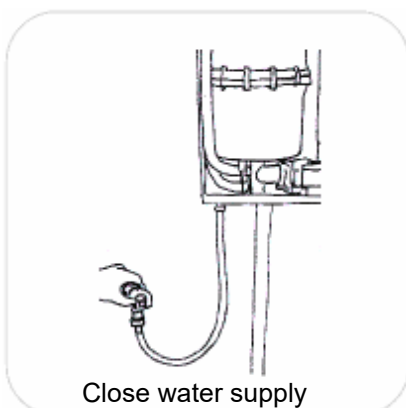

Close water supply



- » Separate steam hose adaptor from steam cylinder

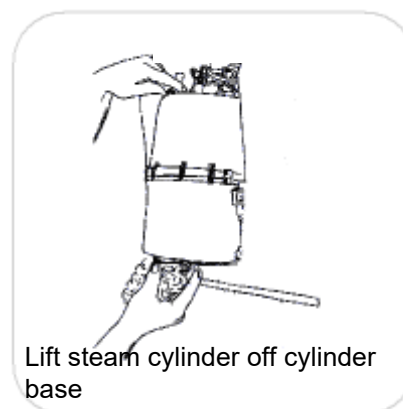

⚠ CAUTION

Risk of eye injuries!

The clips that fix the steam cylinder halves have sharp edges and can jump off during dismantling.

Eye injuries are possible.

Wear proper PPE (Personal Protection Equipment)!

Reinstallation

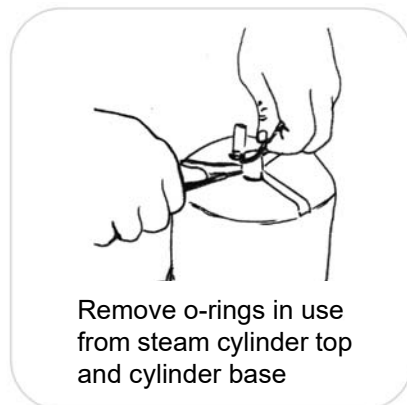
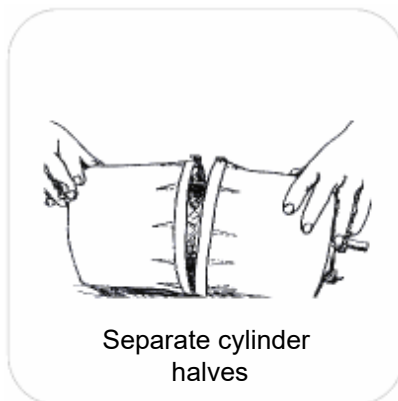
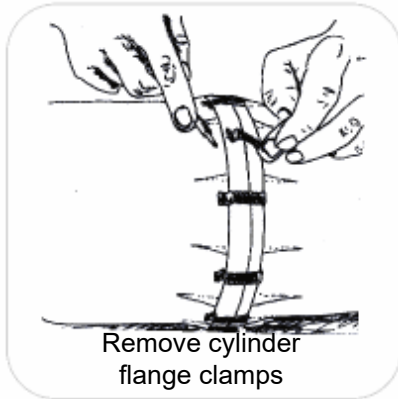

**Please note**

The colour of each electrode wire must correspond to the colour of the handnut of that electrode.

Please note

The electrode connections must not show any signs of corrosion. Replace plugs, if required. Plugs must sit firmly on the electrode pins and must be pushed down as far as they will go.

- » Moisten o-ring in steam hose adaptor and push steam hose adaptor back on steam cylinder.

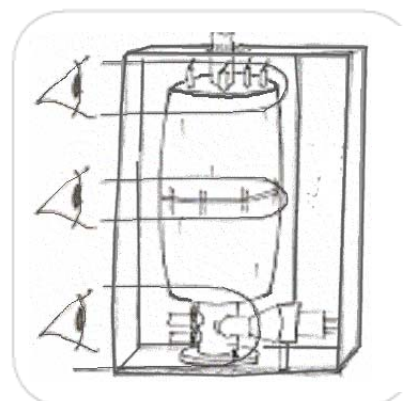
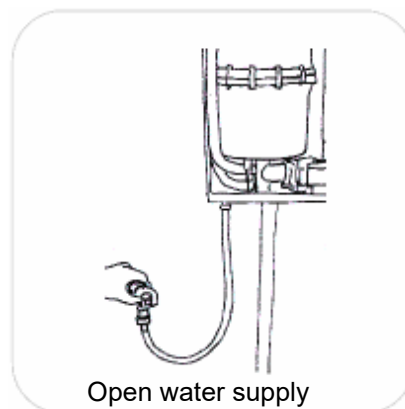
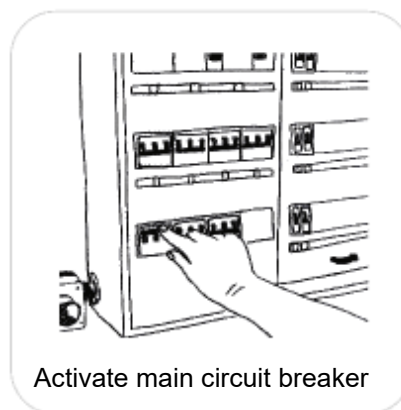

9.4 Steam cylinder, electrodes and cylinder base cleaning

For cleaning, mechanical removal of the deposits is usually sufficient.

NOTICE

Risk of functional disruption!

When using acids or other chemicals for cleaning, thoroughly flushing and rinsing is essential otherwise cylinder water conductivity may be impaired.

Steam cylinder cleaning



- » Check the inside of the top part of steam cylinder for crust build-up and possible salt bridges (black grooves between the electrode leads). If present, wash away/scrape off completely.

Please note

If electrical arcs have burned deep grooves into the material, the complete cylinder must be replaced.

Electrode cleaning

- » Clean the sensor electrode until metallically bright.
- » Clean electrodes and check electrode wear (s. „Changing electrodes“ section).

Cylinder base cleaning

- » Just as the cylinder, the cylinder base and its connection joints must be checked for deposits and be cleaned, if required.

Reinstallation of the steam cylinder is to be performed as described in the „Cylinder removal and reinstallation“ section.

9.5 Checking cable connections

NOTICE

Risk of functional disruption!

Risk of material damage!

Loose cable connections may result in increased transition resistance and contact area overheating.

- » Check all cabling screw terminals and plugs for tight seating. Plugs must sit on their respective contacts as far as they will go.

9.6 Solenoid valve removal/reinstallation and fine filter cleaning

Removal

- » Shut off water supply and disconnect tap water hose cap screw connection.
- » Remove connecting hose (20) from cylinder base.
- » Detach electrical cable connector from solenoid valve (25).
- » Unscrew solenoid valve mounting screws.
- » Remove solenoid valve from housing bore.

Fine filter cleaning

- » Remove fine filter from solenoid valve tap water connection side and clean under running water.

Reinstallation

- » Reinsert fine filter into solenoid valve.
- » Reinsert solenoid valve with seal in unit housing bore.
- » Bolt-down solenoid valve.
- » Reestablish tap water connection.
- » Reconnect electrical cable to solenoid valve.
- » Reattach connecting hose (20) to cylinder base using clamp.
- » Turn on water tap.
- » Switch on unit and check for leakages after 15 to 30 mins of operation.

▲WARNING

Risk of electrical shock!

Hazardous electrical voltage!

Follow safety instruction for work on live components.

Leakages may invoke leak currents.

- » In case of leakage turn off power supply and secure against being switched on again.
- » Find leakage and eliminate.
- » Check again.

9.7 Cleaning of blow-down pump

Removal and cleaning

- » Remove steam cylinder as described in „Removal and reinstallation of steam cylinder“ section.
- » Detach adapter (30) from pump (32).
- » Detach electrical cable from pump.
- » Remove nuts securing pump on console bottom plate.
- » Remove cap nuts securing cylinder base ((37) in exploded view).
- » Remove pump and cylinder base from console and separate.
- » Open pump bayonet lock.
- » Remove residues from pump and drain hoses (replace O-ring (34) if required).

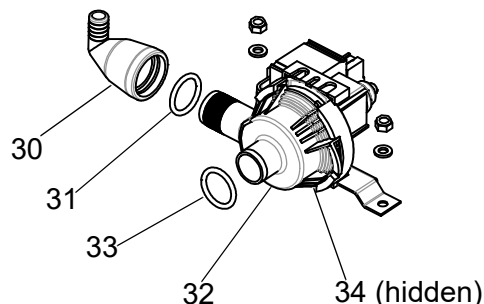

▲ WARNING

Risk of electrical shock!

Hazardous electrical voltage!

Follow safety instructions for work on live components.

Leakages may invoke leak currents.

Reinstallation

- » Moisten O-ring (33) and insert into cylinder base (37) horizontal stub.
- » Push pump back into cylinder base and position the combination of pump and base on the stud bolts of the console.
- » Reattach cap nuts (cylinder base) and nuts (pump).
- » Moisten O-ring (31) and insert into adapter.
- » Slide adapter (30) onto pump stub.
- » Refit electrical cable to pump connector (no polarisation).
- » Let unit run for 15 to 30 mins, then check for leakages.

- » In case of leakage turn off power supply and secure against being switched on again.
- » Find leakage and eliminate.
- » Check again.

9.8 Inspection of hoses

Since steam and condensate hoses are prone to wear as well, those hoses should undergo regular checks as well.

9.9 Electrode replacement

» Remove and open cylinder, as described in section.

- » Plug the electrode plugs (4) directly onto the electrodes (48)
- » Install the steam cylinder

Please note

When mounting the electrodes, make sure that the hand nut colours corresponding with the wiring colours remain in the same position as before in order to omit any unwanted shift of electrical potential. Hence, the hand nut positions must be recorded before they are removed. During reassembly, particular care must be taken to ensure that no grey wire is connected to the electrode plug next to the (grey) sensor electrode hand nut.

» Unscrew hand nuts (49)

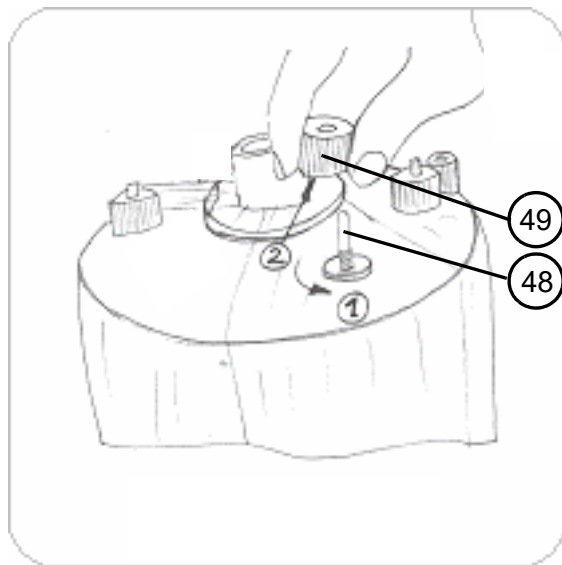

- » Remove electrodes (48)
- » Install new electrodes (48). Make sure that the electrodes are positioned correctly (see exploded view).
- » Hand tighten the nuts (49).
- » Use solvent-free, HygroMatik-quality o-rings (for flange, electrodes, cylinder base and steam hose adapter).
- » Assemble steam cylinder

Genuine electrode length

HygroMatik large area electrodes made from stainless steel have the following genuine lengths:

Model	Length [mm]
KIT E02	80
KIT E06 400 V/3~	125
KIT E06 220 - 240 V/1~/N KIT E10	210
KIT E15	235
KIT E20	210

Electrode wear

Electrode wear depends on:

- composition and conductivity of the supply water
- the amount of steam produced

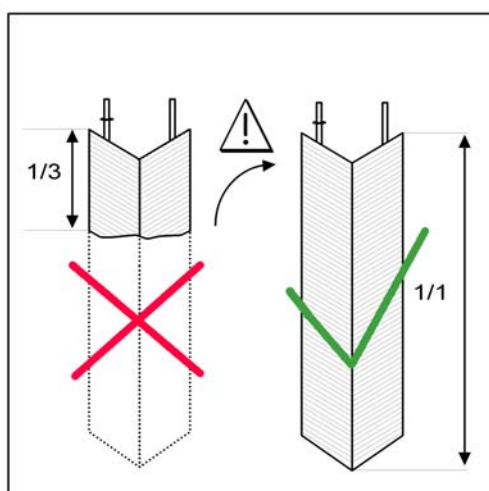

In case of the electrodes being burned-off to less than one third to half of their genuine length, electrode replacement should be made.

Please note

When a HygroMatik control is in use with the kit, an error message is generated and unit operation is cut when the cylinder water max. level is detected for a period of 60 mins. At the latest, electrode replacement should then be made.

9.10 Functional check

- » Run the system with maximum output for a couple of minutes
- » Check all safety devices.
- » Check hose connections and seals for leakage.

10. Dismantling

Once the kit will no longer be used, dismantle (demolish or scrap) it by following the installation procedures in reverse order.

▲ WARNING

Dismantling of the unit may only be performed by qualified personnel. Electrical dismantling may only be performed by trained electricians.

Please note

Obey the safety guidelines in section “Safety Instructions,” especially the guidelines for disposal.

11. Spare parts

*	KitE02	KitE06	KitE10	KitE15	KitE20	Article No.	Description
Steam generation							
16	1					SP-01-00000	Steam cylinder CY02 complete
16		1				B-3216067	Steam cylinder CY04 complete for 380-415V/3
16		1				B-3216119	Steam cylinder CY04 complete for 220-240V/1/N
16			1			SP-03-00000	Steam cylinder CY08 complete
16				1		SP-04-00002	Steam cylinder CY17 complete with 3 electrodes
16					1	SP-04-00000	Steam cylinder CY17 complete with 3 electrodes
48	1					B-3204043	Electrodes without hand nuts, set=2pcs
48		1				B-3216063	Electrodes without hand nuts, set=3pcs
48		1				B-3216053	Electrodes without hand nuts, set=3pcs
48			1			B-3204021	Electrodes without hand nuts, set=3pcs
48				1		B-2204087	Electrodes without hand nuts, set=3pcs
48					1	B-2206221	Electrodes without hand nuts, set=3pcs
38	1					B-3204047	Sensor electrode without hand nut
38		1				B-3204039	Sensor electrode without hand nut
38			1			B-3204029	Sensor electrode without hand nut
38				1	1	B-2204073	Sensor electrode without hand nut
49	1					B-2207099	Hand nuts M6 for cylinder CY2, set=2pcs
49		1	1			B-2207101	Hand nuts M6 for cylinder CY04 and CY08, set=3pcs
49				1	1	B-2207103	Hand nuts M8 for cylinder CY17, set=3pcs
8	1	1	1	1	1	E-2204202	Hand nut M6, grey, for sensor electrode
18	1	1	1	1	1	B-3216021	Cylinder flange clamps, set=24pcs
37	1	1	1			E-3220002	Cylinder base
37				1	1	E-2206090	Cylinder base
1	1	1				E-3221000	Adapter for Steam hose DN25
1			1	1		E-2209018	Adapter for Steam hose DN25
1					1	E-2209008	Adapter for Steam hose DN40
	1					AC-01-00000	O-ringset (Pos. 3, 17, 31, 33, 34, 35, 36)
		1				B-3216071	O-ringset (Pos. 3, 17, 31, 33, 35, 36)
			1			AC-03-00000	O-ringset (Pos. 3, 17, 31, 33, 34, 35, 36)
				1	1	AC-04-00000	O-ringset (Pos. 3, 17, 31, 33, 34, 35, 36)
Water feed							
25	1	1	1			B-2304251	Solenoid valve, SL 1,1l/min, 220-240V, 0,2 - 10bar, with mounting set
25				1	1	B-2304253	Solenoid valve, SL 2,3l/min, 220-240V, 0,2 - 10bar, with mounting set
20	0.4	0.4	0.4	0.5	0.5	E-2604002	Connecting hose solenoid valve - cylinder base [m]
22	3	3	3	3	3	E-8501064	Hose clamp 12-22mm
Water drain							
	1	1	1	1	1	B-2425005	Drain hose system (Pos. 6, 14, 15, 30, 31)
32	1	1	1	1	1	B-2404027	Drain pump without mounting set, with 2 o-rings

* position no. in exploded view

*	KitE02	KitE06	KitE10	KitE15	KitE20	Article No.	Description
							Accessories
	1	1	1	1	1	CN-07-00000	Mainboard of control Standard
	1	1	1	1	1	CN-07-00001	Display StandardLine
	1	1	1	1	1	B-2526201	PCB of control Basic
	1	1	1			WR-03-00001	Connecting cables for electrodes and sensor electrode, Standard control
				1	1	WR-04-00001	Connecting cables for electrodes and sensor electrode, Standard control
	1					B-3526023	Connecting cables for electrodes, Basic control
		1	1			B-3526019	Connecting cables for electrodes, Basic control
				1	1	B-2524249	Connecting cables for electrodes, Basic control
70	x	x	x	x		E-2604012	Steam hose DN25, per m
70					x	E-2604013	Steam hose DN40, per m
	x	x	x	x	x	E-2604002	Condensate hose DN12, per m
	x	x	x	x		E-2404004	Steam hose clamp DN25
					x	E-2604016	Steam hose clamp DN40
	x	x	x	x	x	E-8501064	Condensate hose clamp
	x	x	x	x		E-2604042	Connectors for steam distribution T-piece DN25, stainless steel
					x	E-2604023	Connectors for steam distribution T-piece DN40, stainless steel
	x	x	x	x	x	E-2604021	Connectors for condensate T-piece DN12

* Position no. in der exploded view

Your spare parts order may be directed per e-mail to the Airtrend Ltd office using the address gobrid@eunet.rs

Please make sure to specify your unit model and serial number.

12. Exploded view

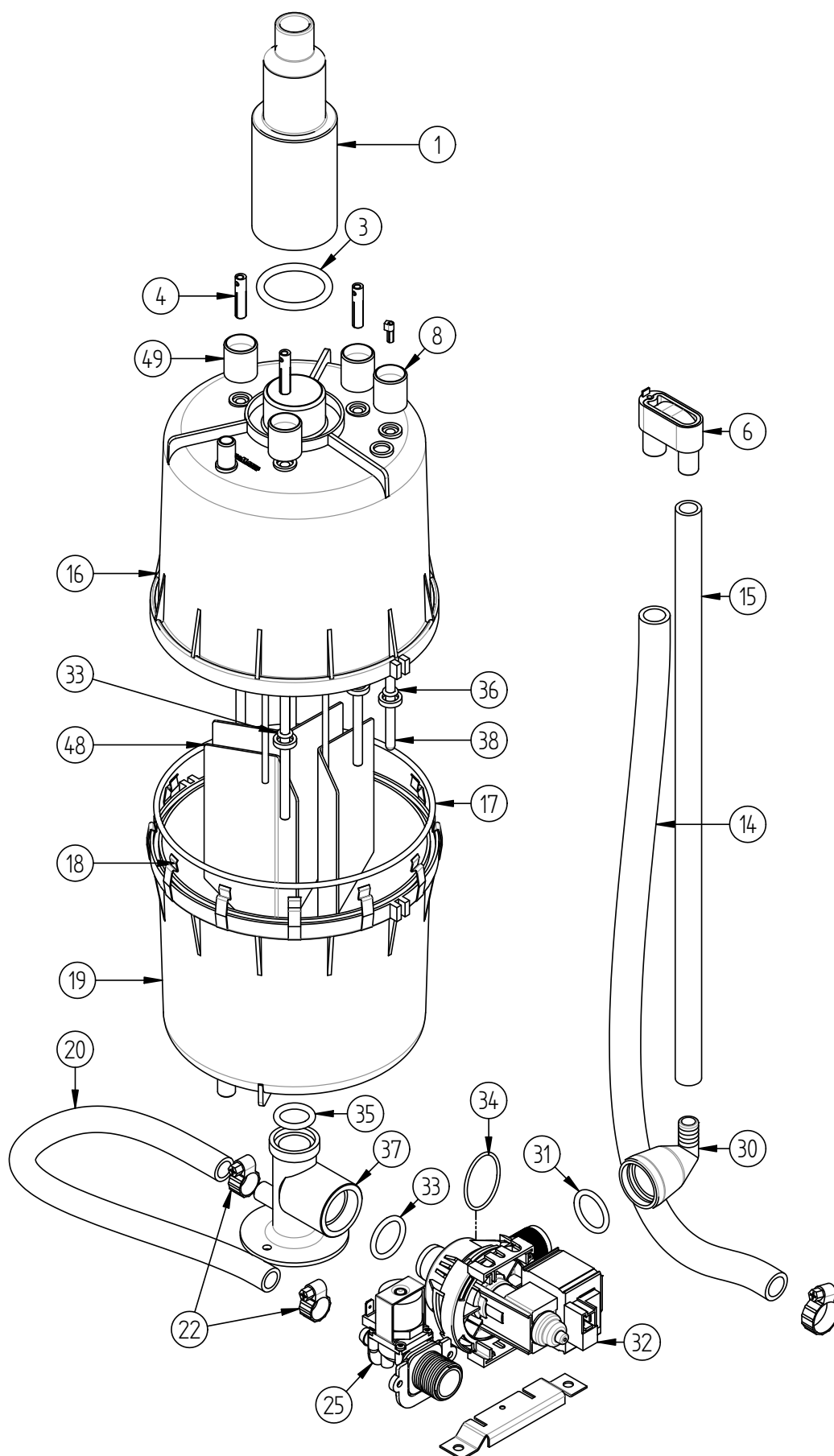

This page intentionally left blank

This page intentionally left blank

13. Technical specifications

Technical specifications SteamKit E						
Model	KIT E02	KIT E06	KIT E10	KIT E15	KIT E20	
Steam output [kg/h]	1.8 - 2.1	4.2 - 4.8	5.6 - 6.3	9.5 - 0.4	14.3 - 15.6	19.0 - 20.8
Electrical supply (with control Standard ⁽¹⁾)	208 - 240 V/1~/N/50 - 60Hz		380 - 415V/3~/50 - 60 Hz			
Power rating [kW]	1.4 - 1.6	3.1 - 3.6	4.2 - 4.7	7.1 - 7.8	10.7 - 11.7	14.3 - 15.6
Nominal current [A]	6.5	15	6.5	10.8	16.3	21.7
Circuit protection [A] ⁽²⁾	1 x 10	1 x 20	3 x 10	3 x 16	3 x 20	3 x 32
Control	optional: Basic or Standard					
Separate control voltage	208 - 240 V/1~/N/1.6 A					
Steam hose connection [mm]	1 x 25					
Empty weight console [kg]	3.4	3.6	4	4	7	7
Operational weight [kg]	8	7	9	9	21	21
Width [mm]	300					
Height [mm]	400	530	550	550	730	730
Depth [mm]	220					
Water connection	Water / tap water (different qualities); 1 to 10 bar, with 3/4" connection for external thread					
Drain water connection	connection Ø 14 mm					

⁽¹⁾ other voltages on request

⁽²⁾ When kit is run with control Standard, multiply power input by 1.1 after full blow-down.

Note overload capacity of automatic breakers. If necessary, select the next higher rating

HygroMATIK®

AIRTREND Ltd.

Predstavništvo u Beogradu
Kumanovska 14, 11000 Beograd

Tel: 011 383 68 86, 308 57 40

Faks: 011 344 41 13

e-mail: gobrid@eunet.rs

web: www.airtrend.rs

